

**RYOBI  
MITER STAND  
MODEL NO. A18MS01  
REPAIR SHEET**

RYOBI MITER STAND - MODEL NUMBER A18MS01

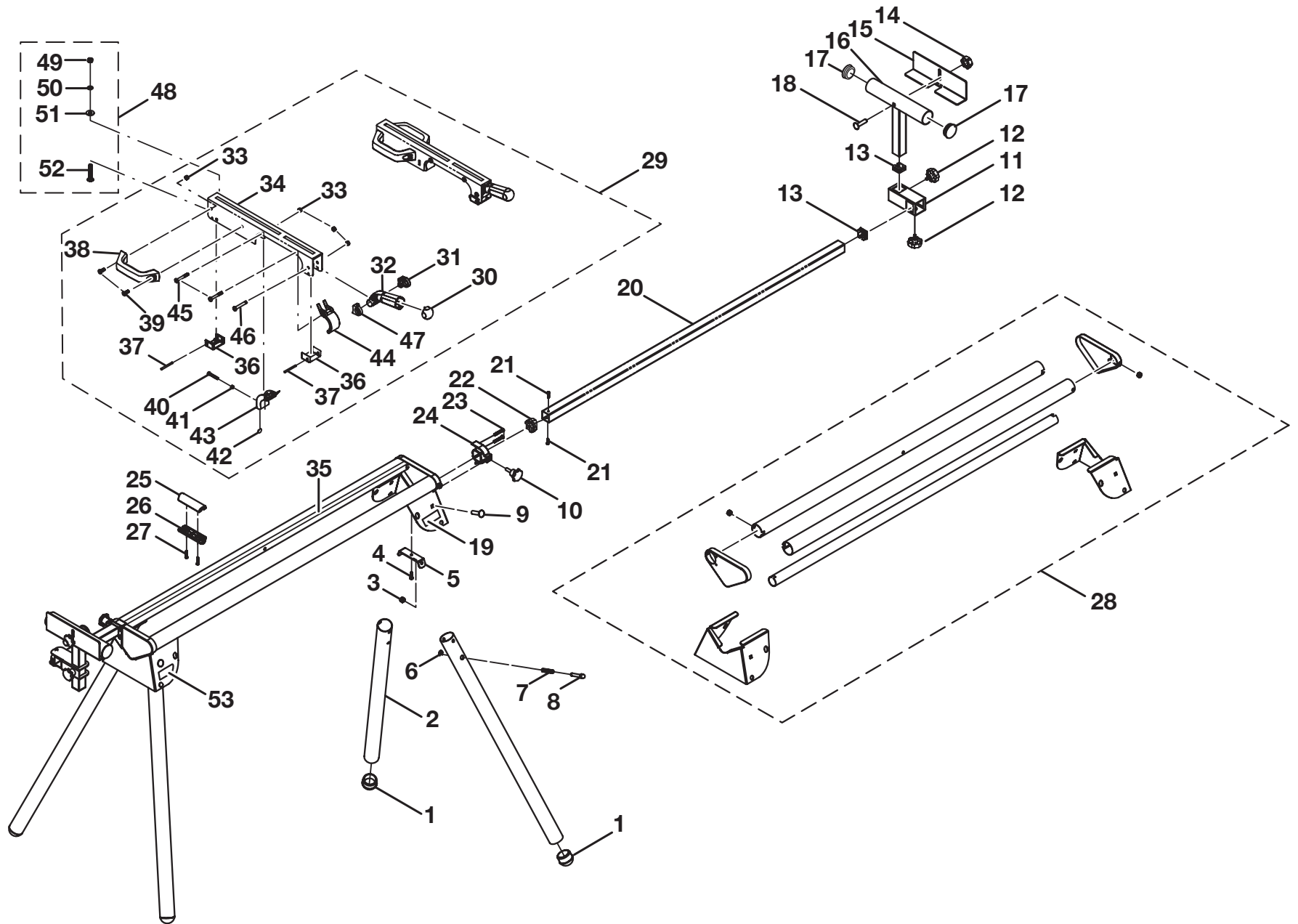

**RYOBI MITER STAND – MODEL NUMBER A18MS01**

**PARTS LIST**

<b>KEY NO.</b>	<b>PART NUMBER</b>	<b>DESCRIPTION</b>	<b>QTY</b>	<b>KEY NO.</b>	<b>PART NUMBER</b>	<b>DESCRIPTION</b>	<b>QTY</b>
1	0000220201	FOOT END CAP.....	4	29	A000220601	SAW MOUNTING BRACKET ASSEMBLY (INC. KEY NOS. 30-34 AND 36-47).....	2
2	0000220301-57	LEG.....	4	30	0131010019	LOCKING LEVER END CAP.....	1
3	411072006	LOCK NUT (M8).....	4	31	0000220216	RIGHT CAM.....	1
4	410132044	* SCREW (M6 X 18 mm PAN HD.).....	2	32	0000220210	HANDLE, M.S. BRACKET.....	1
5	0000220302-82	LEG SUPPORT BRACKET.....	2	33	411072001	* LOCK NUT (M6).....	5
6	413052002	E-RING (E6).....	4	34	0000220307-57	SAW MOUNTING BRACKET.....	1
7	0000220901	SPRING.....	4	35	9000225330301	SCALE (MEASURING TAPE).....	2
8	0000220902	LOCKING PIN.....	4	36	0000220211	SAW MOUNTING BRACKET END CAP.....	2
9	0000220801	* CARRIAGE BOLT (M8 X 60 mm).....	4	37	414012034	PIN (D5 X 45 mm).....	2
10	0000220215	EXTENSION ADJUSTMENT KNOB (M8 X 25 mm).....	2	38	0000220212	SAW MOUNTING BRACKET CARRYING HANDLE.....	1
11	0000220303-82	WORK SUPPORT MOUNTING BRACKET.....	2	39	410132044	* SCREW (M6 X 18 mm PAN HD.).....	2
12	0000220202	LENGTH/HEIGHT ADJUSTMENT KNOB (M8 X 15 mm).....	2	40	410132035	* SCREW (M6 X 30 mm PAN HD.).....	1
13	0000220205	SQUARE TUBE END CAP (OUTSIDE).....	4	41	411012004	* HEX NUT (M6).....	1
14	0000220903	WORK STOP ADJUSTMENT KNOB.....	2	42	0000220309	REAR CLAMPING JAW PROTECTOR.....	1
15	0000220304-82	WORK STOP.....	2	43	0000220213	REAR CLAMPING JAW.....	1
16	0000220305	WORK SUPPORT.....	2	44	0000220214	FRONT CLAMPING JAW.....	1
17	0000220204	WORK SUPPORT END CAP.....	4	45	0000220803	SCREW A (PAN HD. - SPECIAL).....	2
18	410032015	* CARRIAGE BOLT (M6 X 60 mm).....	2	46	0000220804	SCREW B (PAN HD. - SPECIAL).....	1
19	9000225330101	LOGO LABEL.....	2	47	0000220217	LEFT CAM.....	1
20	0000220306	EXTENSION RAIL.....	2	48	A000221501	MOUNTING BRACKET SCREW SET.....	1
21	410452004	* SCREW (M4 X 10 mm PAN HD.).....	4	49	411012706	* HEX NUT (5/16 in.).....	4
22	0000220206	EXTENSION RAIL END CAP (INSIDE).....	2	50	412022706	* WASHER (5/16 in.).....	4
23	410102008	* SCREW (M5 X 12 mm FLAT HD.).....	4	51	412012704	* WASHER (5/16 X D16 X 1.2t).....	4
24	0000220207	EXTENSION RAIL LOCATOR BRACKET.....	2	52	410032716	* CARRIAGE BOLT (5/16-18 X 2 in.).....	4
25	0000220208	MITER SAW STAND UPPER HANDLE.....	1	53	9000225330201	WARNING LABEL.....	2
26	0000220209	MITER SAW STAND LOWER HANDLE.....	1		983000710	OPERATOR'S MANUAL (9000225330501)	
27	410542004	* SCREW (M4 X 16 mm TRUSS HD.).....	2		983000710R	REPAIR SHEET (REV:02)	
28	A000226301-82	WORK FRAME ASSEMBLY.....	1		4-10-06		

\* STANDARD HARDWARE ITEM – MAY BE PURCHASED LOCALLY