

**RYOBI**  
**12 in. DRILL PRESS W/LASER**  
**MODEL NO. DP121L**  
**REPAIR SHEET**

RYOBI 12 in. DRILL PRESS - MODEL NUMBER DP121L

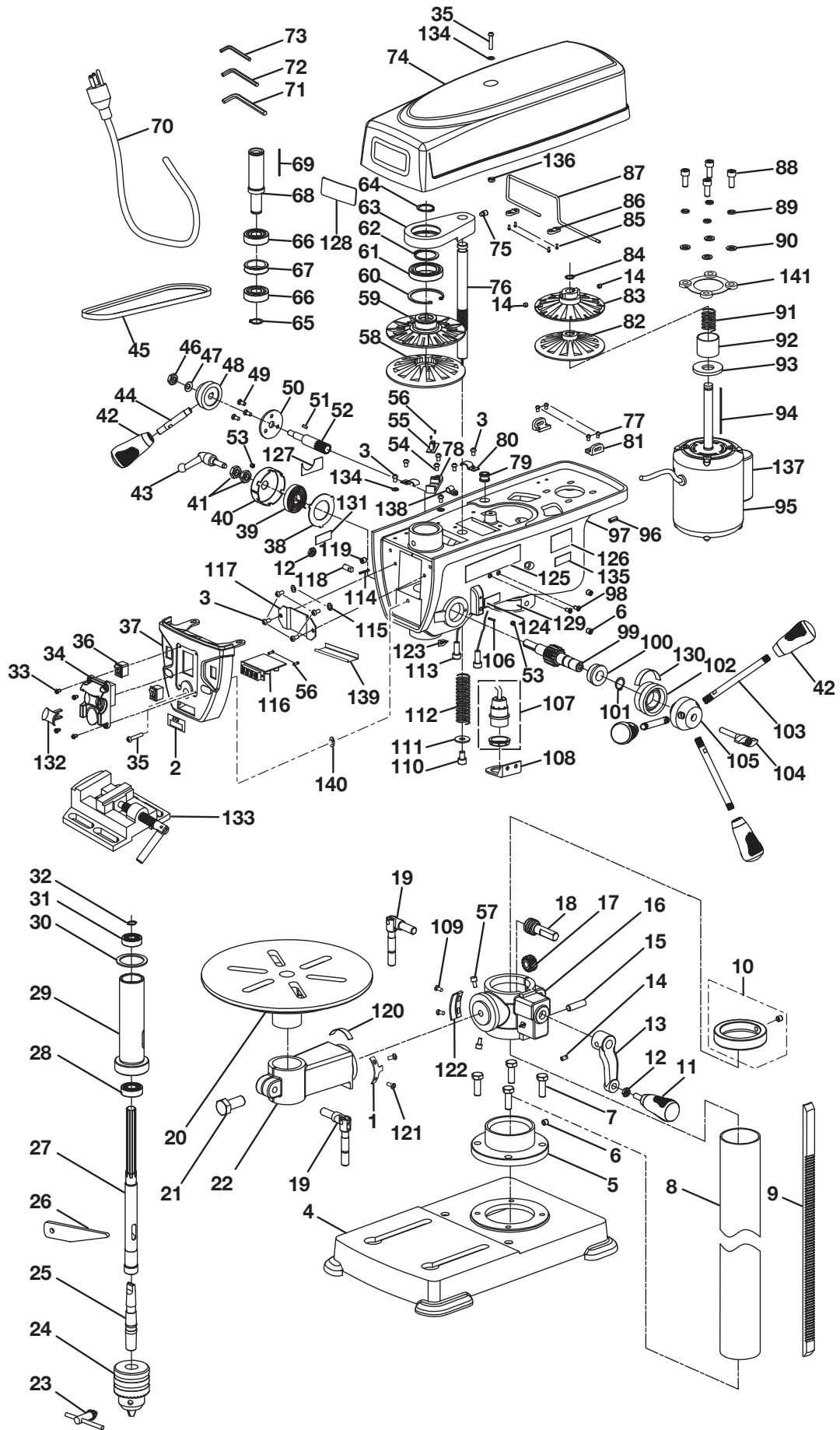

## RYOBI 12 in. DRILL PRESS – MODEL NUMBER DP121L

The model number will be found on a plate attached to the motor housing. Always mention the model number in all correspondence regarding your **DRILL PRESS** or when ordering repair parts.

### PARTS LIST FOR FIGURE A

KEY PART NO. NUMBER	DESCRIPTION	QTY.	KEY PART NO. NUMBER	DESCRIPTION	QTY.		
1	089140300080	BEVEL STOP.....	1	36	089140200044	LIGHT SWITCH.....	2
2	089140300906	RPM LABEL .....	1	37	089140300019	SWITCH BOX.....	1
3	TDP07001	* SCREW (M5 X 6 mm PAN HD.).....	9	38	16104007A	SPRING RETAINER.....	1
4	089140300001	BASE.....	1	39	16104009	TORSION SPRING.....	1
5	13401002A	COLUMN HOLDER.....	1	40	16104008	CAP SPRING .....	1
6	TDP03001	* SET SCREW (M8 X 10 mm HEX SOC.) ....	3	41	TDP12B06005	HEX NUT (M12).....	2
7	089140300003	* BOLT (M10 X 30 mm HEX)..	4	42	089140200083	KNOB.....	4
8	13401003A	TUBE COLUMN .....	1	43	089140300024	HANDLE CLAMP .....	1
9	13201010A	RACK .....	1	44	089140300025	FEED HANDLE.....	1
10	089140300090	COLUMN COLLAR .....	1	45	089140300026	V BELT .....	1
11	089140200022	KNOB.....	1	46	TDP06002	* HEX NUT (M10 mm).....	1
12	TDP06001	* HEX NUT (M8).....	2	47	089140300027	LOCK WASHER (20-1).....	1
13	089140200024	CRANK.....	1	48	089140300028	SPEED ADJUST-HUB .....	1
14	089140300007	* SCREW (M6 X 8 mm HEX SOC.) .....	3	49	089140300029	* SCREW (M5 X 12 mm PAN HD.).....	3
15	13201007	GEAR SHAFT .....	1	50	089140300030	COLLAR SHAFT .....	1
16	13401004B	TABLE SUPPORT.....	1	51	089140300031	KEY (M3 X 6 mm).....	1
17	13201006	WORM GEAR .....	1	52	089140300032	PINION SHAFT.....	1
18	13201008	GEAR .....	1	53	089140200071	* SCREW (M6 X 5 mm HEX SOC.).....	2
19	16101013A	TABLE LOCK HANDLE .....	2	54	089140300033	* SCREW (M4 X 16 mm PAN HD.).....	2
20	089140300010	TABLE .....	1	55	089140300034	SENSOR .....	1
21	TDP12B03009	* SCREW (M12 X 25 mm HEX HD.).....	1	56	089140300035	* SCREW (M2.2 X 6.5 mm)....	4
22	13401005	ARM-TABLE.....	1	57	089140300036	* SCREW (M5 X 8 mm HEX SOC.).....	2
23	13103006M1	CHUCK KEY .....	1	58	089140300037	SPINDLE PULLEY-LOWER..	1
24	13103006M	CHUCK .....	1	59	089140300038	SPINDLE PULLEY-UPPER..	1
25	13403007	ARBOR.....	1	60	089140300039	C-CLIP (SPINDLE PULLEY)	1
26	16103008	CHUCK TOOL (DRIFT).....	1	61	089140300040	BEARING (61907) .....	1
27	13303001A	SPINDLE.....	1	62	089140300041	RETAINING RING (35).....	1
28	089140300015	BEARING (80204) .....	1	63	089140300042	DRIVE PLATE .....	1
29	13303002A	QUILL TUBE .....	1	64	089140300043	RETAINING RING (24).....	1
30	13303006	QUILL GASKET.....	1	65	TDP10002	RETAINING RING (17).....	1
31	TDP02001	BALL BEARING (60201).....	1	66	089140200039	BALL BEARING (60203).....	2
32	TDP10001	RETAINING RING (11) .....	1	67	13302023A	SPACER.....	1
33	089140200036	* SCREW (M3.5 X 9.5 mm PAN HD.)...	4	68	089140300045	INSERT PULLEY .....	1
34	089140200037	SWITCH .....	1	69	089140300046	KEY (M4 X 60 mm).....	1
35	089140200035	* SCREW (M5 X 25 mm PAN HD.).....	2	70	089140300047	POWER CORD.....	1
				71	089140200082	HEX KEY (5 mm) .....	1

\* Standard Hardware Item – May Be Purchased Locally

## RYOBI 12 in. DRILL PRESS – MODEL NUMBER DP121L

The model number will be found on a plate attached to the motor housing. Always mention the model number in all correspondence regarding your **DRILL PRESS** or when ordering repair parts.

### PARTS LIST FOR FIGURE A

KEY PART NO. NUMBER	DESCRIPTION	QTY.	KEY PART NO. NUMBER	DESCRIPTION	QTY.	
72	TDP04001	HEX KEY (4 mm).....	1	109	089140300083 * SCREW (M4 X 12 mm PAN HD.).....	2
73	089140200080	HEX KEY (3 mm).....	1	110	089140300072 * SCREW (M8 X 16 mm HEX SOC.)....	1
74	089140300048	PULLEY COVER.....	1	111	089140300073 WASHER (M8).....	1
75	089140300049	* SCREW (SET W/DOG POINT M8 X 16 mm HEX SOC.).....	1	112	089140300074 SPRING.....	1
76	089140300050	RACK.....	1	113	089140200032 LASER LIGHT.....	2
77	089140200067	* SCREW (M4 X 8 mm PAN HD.).....	4	114	089140200030 * ROLL PIN (D2.5 X 16 mm) ..	1
78	089140300052	SENSOR SEAT.....	1	115	TDP08001 EXT. TOOTH LOCK WASHER (M5).....	2
79	089140200031	RUBBER GROMMET.....	2	116	089140300076 LED ASSEMBLY.....	1
80	13202014A	CORD CLAMP W/SLEEVE..	2	117	089140300077 BAFFLE.....	1
81	089140300053	GEMEL SEAT.....	2	118	13202021 SPECIAL SET SCREW.....	1
82	089140300054	MOTOR PULLEY-LOWER ..	1	119	TDP03002 * HEX SCREW (M8 X 8 mm)..	1
83	089140300055	MOTOR PULLEY-UPPER ...	1	120	089140300901 SCALE LABEL (FOR BRACKET).....	1
84	089140300056	RETAINING RING (14).....	1	121	089140300078 * SCREW (M5 X 8 mm PAN HD.).....	2
85	089140300057	* SCREW (M4.2 X 9.5 mm PAN HD.)...	4	122	13406002A TABLE INDICATOR.....	1
86	089140300058	GEMEL CLAMP.....	2	123	089140200903 DEPTH (STROKE) INDICATOR.	1
87	089140300059	GEMEL.....	1	124	089140200905 LASER WARNING LABEL-1..	1
88	089140300060	* SCREW (M8 X 25 mm HEX SOC.)....	4	125	089140300903 WARNING LABEL.....	1
89	TDP11001	LOCK WASHER (M8).....	4	126	089140300904 DATA LABEL.....	1
90	089140300062	WASHER (M8).....	4	127	089140300905 SPEED ADJUST LABEL.....	1
91	089140300063	MOTOR PULLEY SPRING ..	1	128	089140200908 LOGO LABEL.....	1
92	089140300064	HOOD SPRING.....	1	129	089140200909 LAMP WATT LABEL.....	1
93	089140300065	PALLET SPRING.....	1	130	089140300907 DEPTH SCALE LABEL.....	1
94	089140300066	KEY (M4 X 75 mm).....	1	131	089140200911 LASER WARING LABEL-2..	1
95	089140300088	MOTOR.....	1	132	984406003 SWITCH KEY.....	1
96	089140300068	ROLL PIN (D6 X 16 mm) ....	1	133	089140200092 VISE (2.5 in.).....	1
97	089140300069	HEAD STOCK.....	1	134	089140200102 WASHER.....	3
98	089140200087	* SCREW (M4.2 X 13 mm COUNTERSUNK HD.).....	2	135	089140200912 LASER LABEL.....	1
99	089140300070	GEAR SHAFT.....	1	136	089140300081 * HEX NUT (M10 mm).....	1
100	089140200074	SHAFT SEAT.....	1	137	089140300082 CAPACITOR (MOTOR) DP121L.....	1
101	089140200075	RETAINING RING (16).....	1	138	089140300084 CABLE CLAMP.....	1
102	089140200076	DEPTH STOP RING.....	1	139	089140300085 INSULATING TAPE.....	1
103	089140200084	ROD.....	3	140	089140300086 WASHER.....	1
104	089140200086	KNOB DEPTH SCREW.....	1	141	089140300087 MOTOR CUSHION.....	1
105	089140200085	HUB.....	1		983000642 OPERATOR'S MANUAL	
106	089140300071	* ROLL PIN (D2.5 X 12 mm) ..	1		06-06-08	
107	089140200088	BULB SOCKET W/NUT.....	1		(REV:06)	
108	089140200089	BULB SOCKET-BRACKET..	1			

\* Standard Hardware Item – May Be Purchased Locally

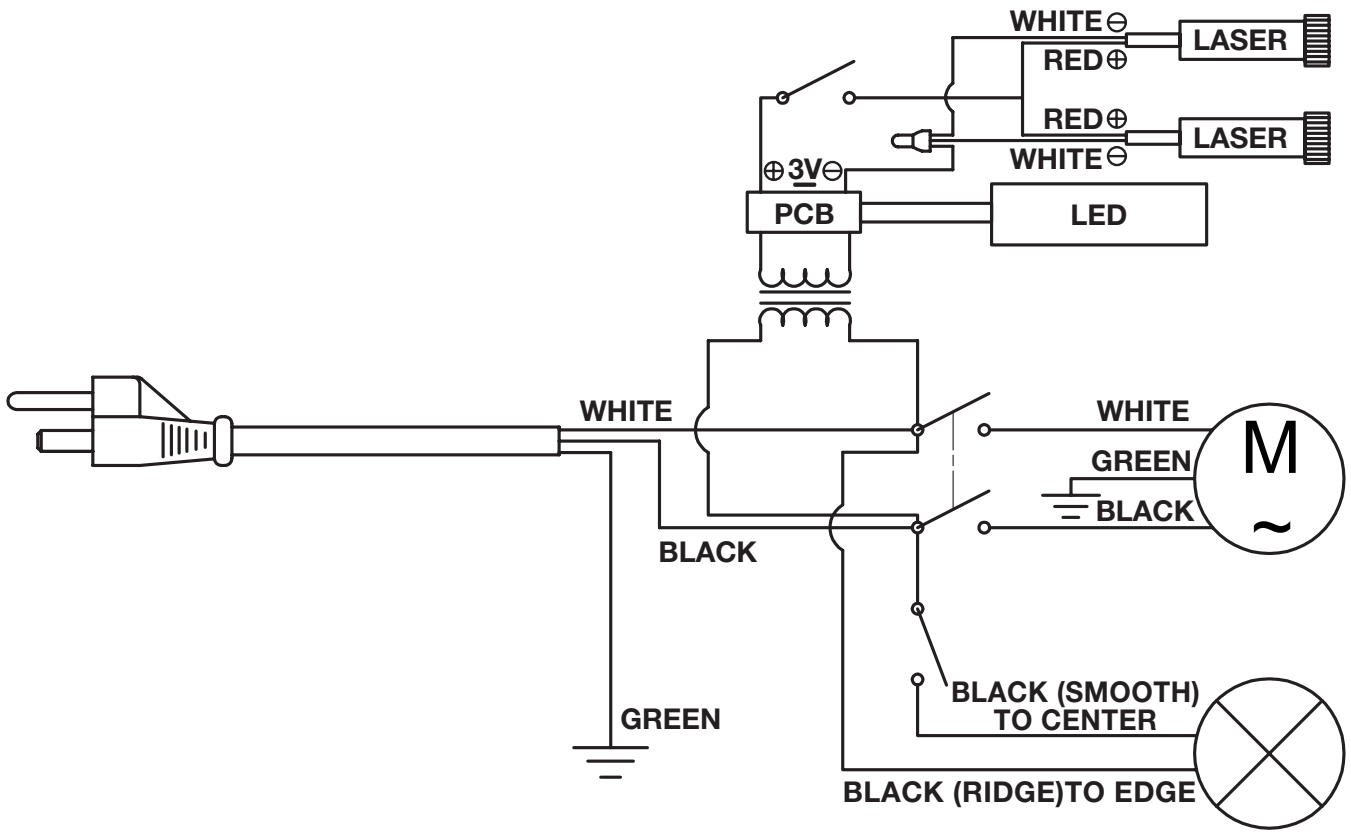

WIRING DIAGRAM