

RYOBI
10 in. DRILL PRESS W/LASER
MODEL NO. DP102L
REPAIR SHEET

RYOBI 10 in. DRILL PRESS - MODEL NUMBER DP102L

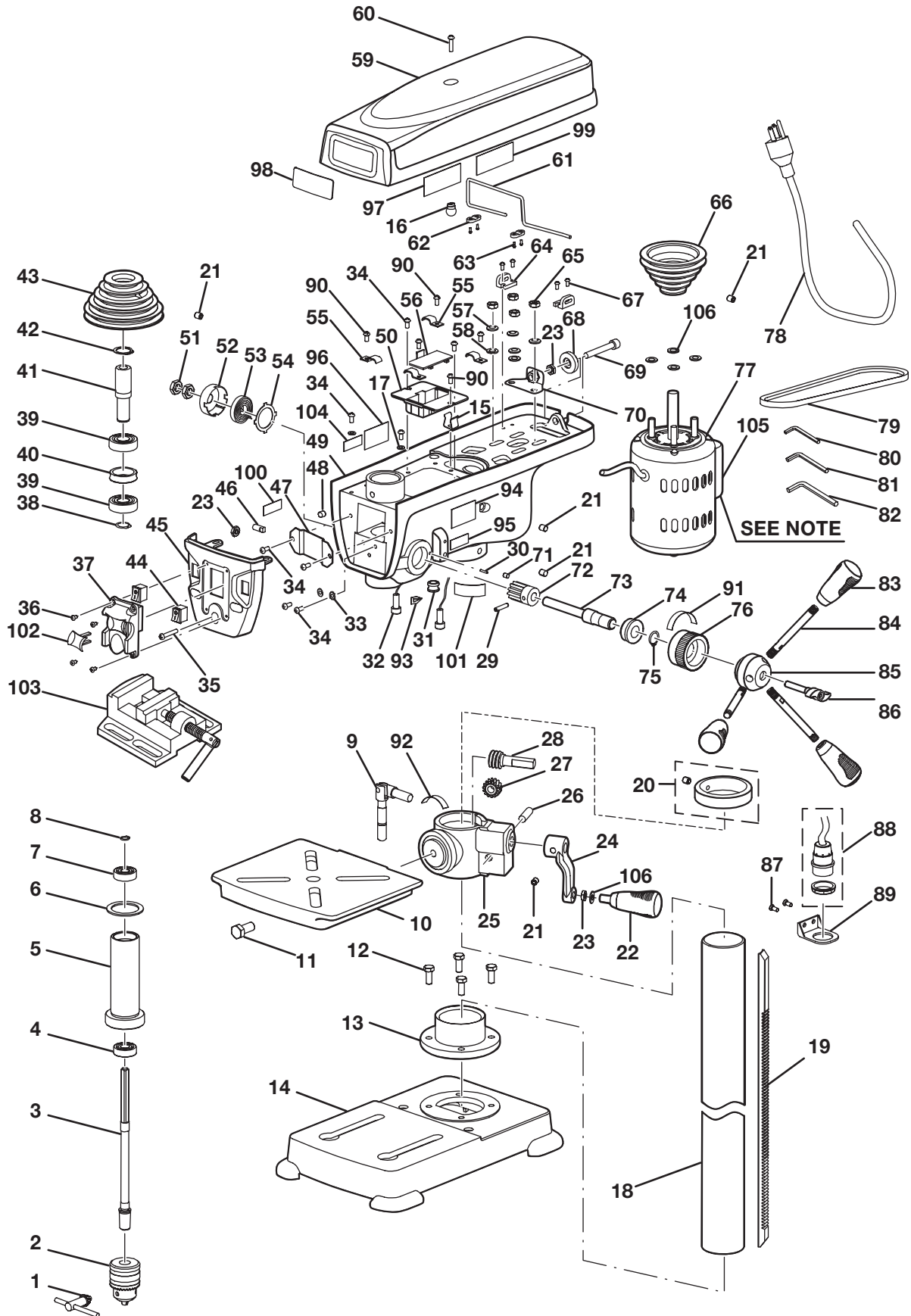

NOTE: The assembly shown represents an important part of the double insulated system. To avoid the possibility of alteration or damage to the system, service should be performed by your nearest Ryobi Authorized Service Center. For the service center nearest you call 1-800-525-2579.

RYOBI 10 in. DRILL PRESS – MODEL NUMBER DP102L

The model number will be found on a plate attached to the motor housing. Always mention the model number in all correspondence regarding your **DRILL PRESS** or when ordering repair parts.

PARTS LIST FOR FIGURE A

KEY NO.	PART NUMBER	DESCRIPTION	QTY.
1	13103006M1	CHUCK KEY.....	1
2	13103006M	CHUCK.....	1
3	13203001A	SPINDLE SHAFT.....	1
4	089140200004	BALL BEARING (80201).....	1
5	13203002D	QUILL TUBE.....	1
6	13303006	QUILL GASKET.....	1
7	TDP02001	BALL BEARING (60201).....	1
8	TDP10001	RETAINING RING (11).....	1
9	16101013A	TABLE LOCK HANDLE.....	1
10	13201014D	TABLE.....	1
11	TDP05001	* BOLTS (M12 X 25 mm HEX HD.).....	1
12	TDP01001	* BOLTS (M8 X 20 mm HEX HD.).....	4
13	13201002	BASE COLLAR.....	1
14	089140200014	BASE.....	1
15	089140200015	CLIP.....	1
16	089140200016	BALL.....	1
17	089140200102	WASHER.....	2
18	13201003	COLUMN TUBE.....	1
19	13201010	RACK.....	1
20	089140200097	COLUMN COLLAR.....	1
21	TDP03001	* SCREW (M8 X 10 mm SOC. HD.).....	5
22	089140200022	KNOB.....	1
23	TDP06001	* HEX NUT (M8).....	3
24	089140200024	CRANK.....	1
25	089140200025	TABLE SUPPORT.....	1
26	13201007	GEAR SHAFT.....	1
27	13201006	GEAR.....	1
28	13201008	WORM GEAR.....	1
29	089140200029	ROLL PIN (D4 X 24 mm).....	1
30	089140200030	ROLL PIN (D2.5 X 16 mm).....	1
31	089140200031	RUBBER GROMMET.....	2
32	089140200032	LASER LIGHT.....	2
33	TDP08001	TOOTHED LOCK WASHER (M5).....	2
34	TDP07001	* SCREW (M5 X 6 mm PAN HD.).....	9
35	089140200035	* SCREW (M5 X 25 mm PAN HD.).....	1
36	089140200036	* SCREW (M3.5 X 9.5 mm PAN HD.).....	4
37	089140200037	SWITCH.....	1
38	TDP10002	RETAINING RING (17).....	1
39	089140200039	BALL BEARING (60203).....	2
40	13302023A	SPACER.....	1
41	089140200041	PULLEY INSERT.....	1
42	089140200042	RETAINING RING (22).....	1
43	089140200043	PULLEY SPINDLE.....	1
44	089140200044	LIGHT SWITCH.....	2
45	089140200045	SWITCH BOX.....	1
46	13202021	SPECIAL SET SCREW.....	1
47	089140200047	BAFFLE.....	1
48	TDP03002	* SCREW (M8 X 8 mm HEX HD.).....	1
49	089140200049	HEAD STOCK.....	1
50	089140200050	BATTERY BOX.....	1
51	TDP06002	* HEX NUT (M10).....	2
52	13104008	SPRING CAP.....	1
53	13104009	TORSION SPRING.....	1
54	13104007	SPRING RETAINER.....	1
55	13202014	CORD CLAMP.....	4

* Standard Hardware Item – May Be Purchased Locally

RYOBI 10 in. DRILL PRESS – MODEL NUMBER DP102L

The model number will be found on a plate attached to the motor housing. Always mention the model number in all correspondence regarding your **DRILL PRESS** or when ordering repair parts.

PARTS LIST FOR FIGURE A

KEY NO.	PART NUMBER	DESCRIPTION	QTY.
56	089140200056	BATTERY BOX CAP	1
57	089140200057	LOCK WASHER (16-1)	4
58	TDP11002	* WASHER (M8)	2
59	089140200059	GUARD.....	1
60	089140200035	* SCREW (M5 X 25 mm PAN HD.).....	1
61	089140200061	GEMEL	1
62	089140200062	CLAMP GEMEL.....	2
63	089140200063	* SCREW (M4.2 X 9.5 mm PAN HD.).....	4
64	089140200064	SEAT GEMEL.....	2
65	089140200065	* HEX NUT (M8)	4
66	089140200066	MOTOR PULLEY.....	1
67	089140200067	* SCREW (M4 X 8 mm PAN HD.).....	4
68	089140200068	BELT TENSION KNOB	1
69	089140200069	* SCREW (M8 X 60 mm HEX SOC. HD.)	1
70	089140200070	MOTOR ADJUST PLATE	1
71	089140200071	* SCREW (M6 X 5 mm HEX SOCKET).....	1
72	089140200072	GEAR.....	1
73	089140200073	SHAFT	1
74	089140200074	SHAFT SEAT	1
75	089140200075	RETAINING RING (16)	1
76	089140200076	DEPTH STOP RING	1
77	089140200103	MOTOR (INC. KEY NO. 105).....	1
78	13202016	POWER CORD	1
79	13205007	BELT (K31).....	1
80	089140200080	* HEX KEY (3 mm)	1
81	TDP04001	* HEX KEY (4 mm)	1
82	089140200082	* HEX KEY (5 mm)	1
83	089140200083	KNOB	3
84	089140200084	ROD.....	3
85	089140200085	HUB.....	1
86	089140200086	KNOB DEPTH SCREW.....	1
87	089140200087	* SCREW (M4.2 X 13 mm COUNTERSUNK HD.).....	2
88	089140200088	BULB SOCKET WITH NUT	1
89	089140200089	BULB SOCKET-BRACKET	1
90	089140200095	SCREW (M5 X 8 mm PAN HD.).....	3
91	089140200901	DEPTH SCALE	1
92	089140200902	BRACKET-SCALE	1
93	089140200903	DEPTH (STROKE) INDICATOR.....	1
94	089140200904	WARNING LABEL	1
95	089140200905	LASER WARNING LABEL-1	1
96	089140200906	DATA LABEL.....	1
97	089140200907	LABEL (SPEED CHART-1).....	1
98	089140200908	LOGO LABEL	1
99	089140200910	LABEL (SPEED CHART-2).....	1
100	089140200911	LASER WARNING LABEL-2.....	1
101	089140200909	LAMP WATT LABEL	1
102	984406003	SWITCH KEY.....	1
103	089140200092	VICE (2.5 in.)	1
104	089140200912	LASER LABEL	1
105	089140200094	CAPACITOR (DP102 MOTOR)	1
106	089140200096	WASHER	5
	983000641	OPERATOR'S MANUAL	
	06-06-08		
	(REV:05)		

* Standard Hardware Item – May Be Purchased Locally

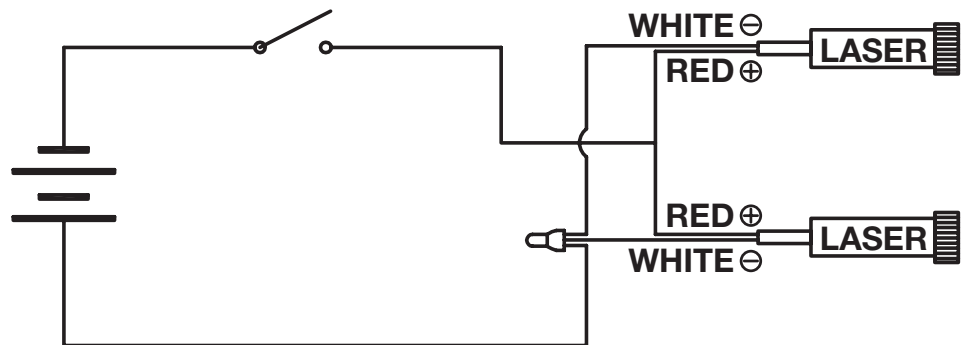
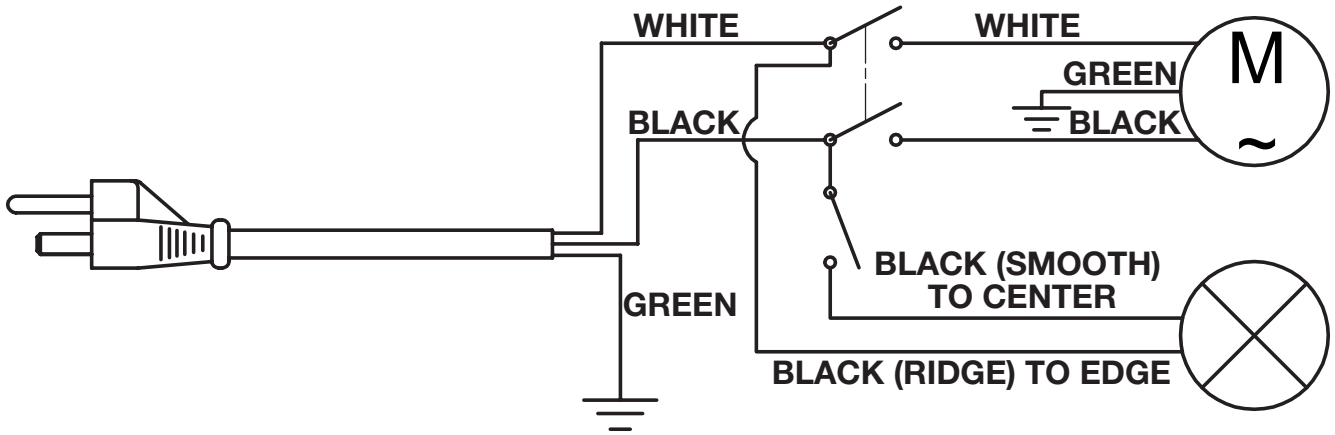

WIRING DIAGRAM