

RYOBI
13 in. PLANER
MODEL NO. AP1301
REPAIR SHEET

RYOBI 13 in. PLANER - MODEL NUMBER AP1301

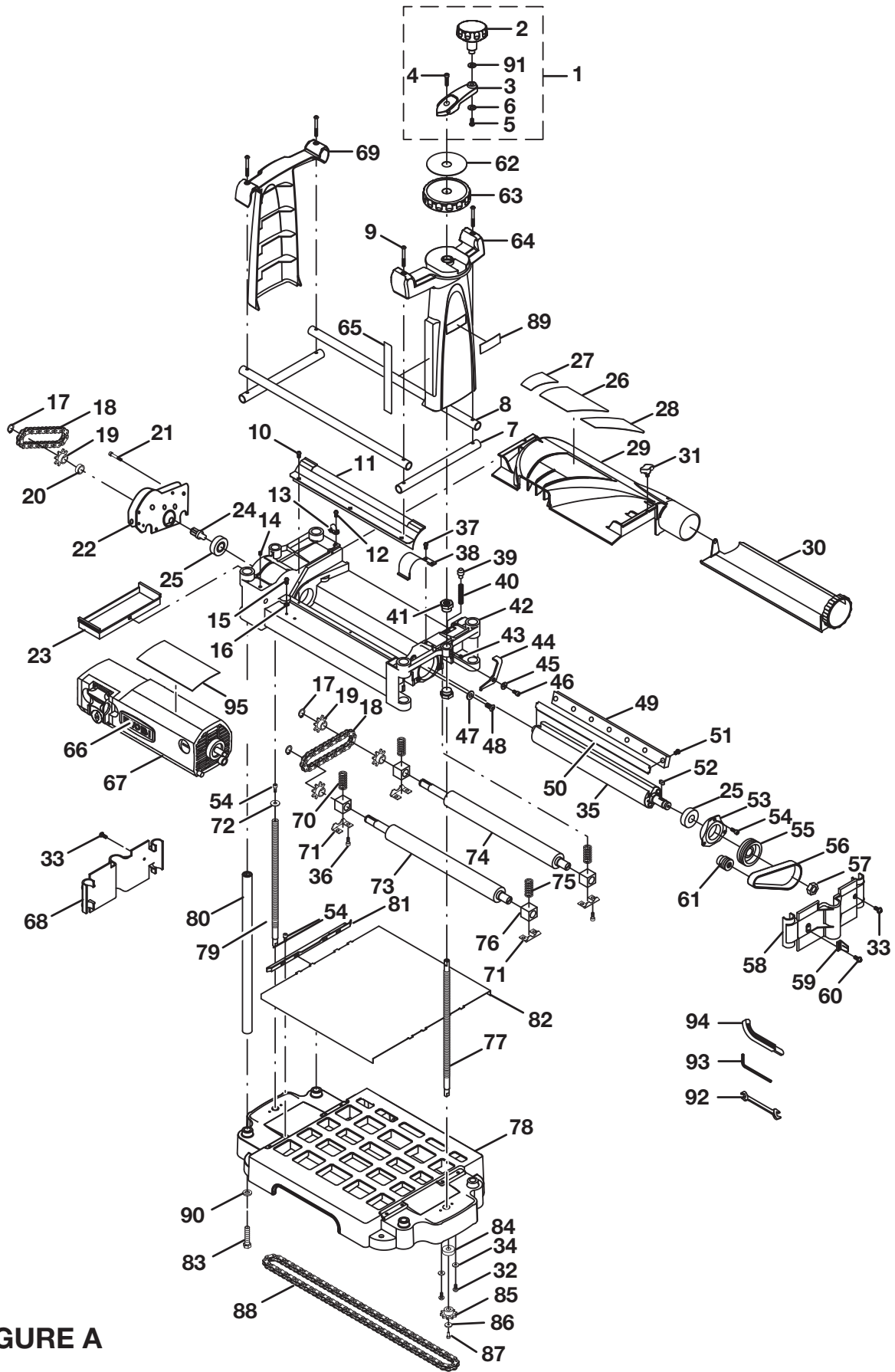

FIGURE A

RYOBI 13 in. PLANER – MODEL NUMBER AP1301

The model number will be found on a plate attached to the motor housing. Always mention the model number in all correspondence regarding your **PLANER** or when ordering repair parts.

PARTS LIST FOR FIGURE A

KEY NO.	PART NUMBER	DESCRIPTION	QTY.
1	089170101800	HANDLE ASSEMBLY (INC. KEY NOS. 2-6 AND 91).....	1
2	089170101001	HANDLE KNOB ASSEMBLY	1
3	089170101002	HANDLE ARM ASSEMBLY	1
4	089170101003	* SCREW (M5 X P0.8 X 20 mm HEX SOC.).....	1
5	089170101008	* SCREW (M4 X P0.7 X 12 mm HEX SOC.).....	1
6	089170101010	* WASHER (Ø4.3 X Ø12 X 1t)	1
7	089170101011	CONNECTION TUBE - SHORT (OD.20 X 1.0t X 225 mm)	2
8	089170101012	CONNECTION TUBE - LONG (OD.20 X 1.0t X 485 mm)	2
9	089170101013	* SCREW (M6 X P1 X 60 mm SOC. BUTTON HD.)	4
10	089170101014	* SCREW (M5 X P0.8 X 8 mm PAN HD.)	3
11	089170101015	DUST CHUTE PLATE	1
12	089170101016	* SCREW W/WASHER (M5 X P0.8 X 10 mm).....	1
13	827767	CORD CLAMP	1
14	821065-2	SET SCREW (M5 X P0.8 X 8 mm)	1
15	089170101019	* SCREW (M5 X P0.8 X 8 mm PAN HD.)	2
16	813314-8	LOCK WASHER (M5)	2
17	817453	RETAINING RING.....	3
18	827794	CHAIN	2
19	827772	SPROCKET	4
20	827773	SPACER	1
21	828943-4	* SCREW (M5 X P0.8 X 35 mm HEX SOC.).....	4
22	089170101801	GEARBOX ASSEMBLY	1
23	089170101038	GEAR BOX COVER	1
24	827784	PINION	1
25	820722-5	BALL BEARING (6203ZZ)	2
26	089170101900	WARNING LABEL (DUST CHUTE-1).....	1
27	089170101907	WARNING LABEL (DUST CHUTE-2).....	1
28	089170101908	WARNING LABEL (DUST CHUTE-3).....	1
29	089170101041	CHUTE DUST (INC. KEY NOS. 26-28).....	1
30	089170101042	HOOD DOOR	1
31	089170101043	HURRICANE KNOB	2
32	089170101044	* SCREW (M5 X P0.8 X 10 mm PAN HD.)	4
33	089170101045	* SCREW (M5 X P0.8 X 10 mm HEX HD.)	2
34	089170101046	* WASHER (Ø5.2 X Ø16 X 1.5t)	4
35	827680	CUTTER HEAD.....	1
36	089170101137	* SCREW (M5 X P0.8 X 10 mm HEX SOC.).....	1
37	089170101047	* SCREW W/WASHER (M4 X P0.7 X 10 mm).....	2
38	089170101048	BELT GUARD	1
39	828788	PLUNGER	1
40	827738	SPRING COIL.....	1
41	089170101051	ELEVATION NUT (14 mm).....	4
42	089170101052	UPPER FRAME	1
43	821065-1	* SCREW (M5 X P0.8 X 5 mm).....	4
44	089170101054	CUTTER HEAD LOCK	1
45	827737	SPACER	1
46	828027	* SCREW (M5 X P0.8 X 12 mm HEX SOC.).....	1
47	821063	* WASHER (Ø8 X Ø18 X 2t)	1

* Standard Hardware Item – May Be Purchased Locally

RYOBI 13 in. PLANER – MODEL NUMBER AP1301

The model number will be found on a plate attached to the motor housing. Always mention the model number in all correspondence regarding your **PLANER** or when ordering repair parts.

PARTS LIST FOR FIGURE A

KEY NO.	PART NUMBER	DESCRIPTION	QTY.
48	089170101058	* SCREW (M8 X P1.25 X 20 mm HEX HD.)	1
49	827711	BLADE LOCKING PLATE	2
50	089170101062	PLANER BLADE (19 X 1.8 X 344)	2
51	828791	SCREW	14
52	818654-9	KEY (5 X 12 mm)	1
53	827786	BEARING RETAINER	1
54	820379	* SCREW (M5 X P0.8 X 12 mm HEX SOC.)	14
55	089170101069	PULLEY CUTTER HEAD	1
56	827793	BELT DRIVE (135J6)	1
57	827788	NUT HEX (M16LH X 8t)	8
58	089170101072	SMALL COVER (RIGHT SIDE)	1
59	089170101073	DEPTH INDICATOR	1
60	089170101074	* SCREW W/WASHER (M4 X P0.7 X 8 mm)	1
61	827789	PULLEY MOTOR	1
62	089170101901	ZERO RESET DIAL LABEL	1
63	089170101076	ZERO RESET DIAL	1
64	089170101077	LARGE COVER (RIGHT SIDE)	1
65	089170101902	SCALE LENGTH	1
66	089170101903	LOGO LABEL	1
67	089170101802	MOTOR/SWITCH ASSEMBLY (INC. KEY NOS. 66 AND 95)	1
68	089170101078	SMALL COVER (LEFT SIDE)	1
69	089170101079	LARGE COVER (LEFT SIDE)	1
70	827758	SPRING COIL - LEFT	2
71	AP13084	RETAINER PLATE	4
72	827765	* WASHER (Ø5.5 X Ø19 X 2t)	1
73	828939	ROLLER INFEED	1
74	828938	ROLLER OUTFEED	1
75	827755	SPRING COIL - RIGHT	2
76	AP13089	BEARING BLOCK (23 mm)	4
77	089170101087	R.H. SPINDLE	1
78	089170101088	BASE	1
79	089170101089	L.H. SPINDLE	1
80	089170101803	POST	4
81	827705	RAIL GUIDE	2
82	089170101094	WEAR PLATE	1
83	089170101095	* SCREW (M10 X P1.5 X 40 mm HEX)	4
84	089170101096	BALL BEARING (6000ZZ)	2
85	089170101097	SPROCKET	2
86	089170101098	* WASHER (Ø4 X Ø15 X 2t)	2
87	089170101099	* SCREW (M4 X P0.7 X 12 mm HEX SOC. HD.)	2
88	089170101100	CHAIN	1
89	089170101904	SIDE COVER LABEL	2
90	089170101101	* WASHER (Ø10.5 X Ø21 X 2t)	4
91	089170101007	WASHER	1
92	827756	WRENCH (M8 X M10)	1
93	827757	HEX KEY (M4 X 120 mm)	1
94	089170101103	BLADE WRENCH	1
95	089170101906	MOTOR WARNING LABEL	1

* Standard Hardware Item – May Be Purchased Locally

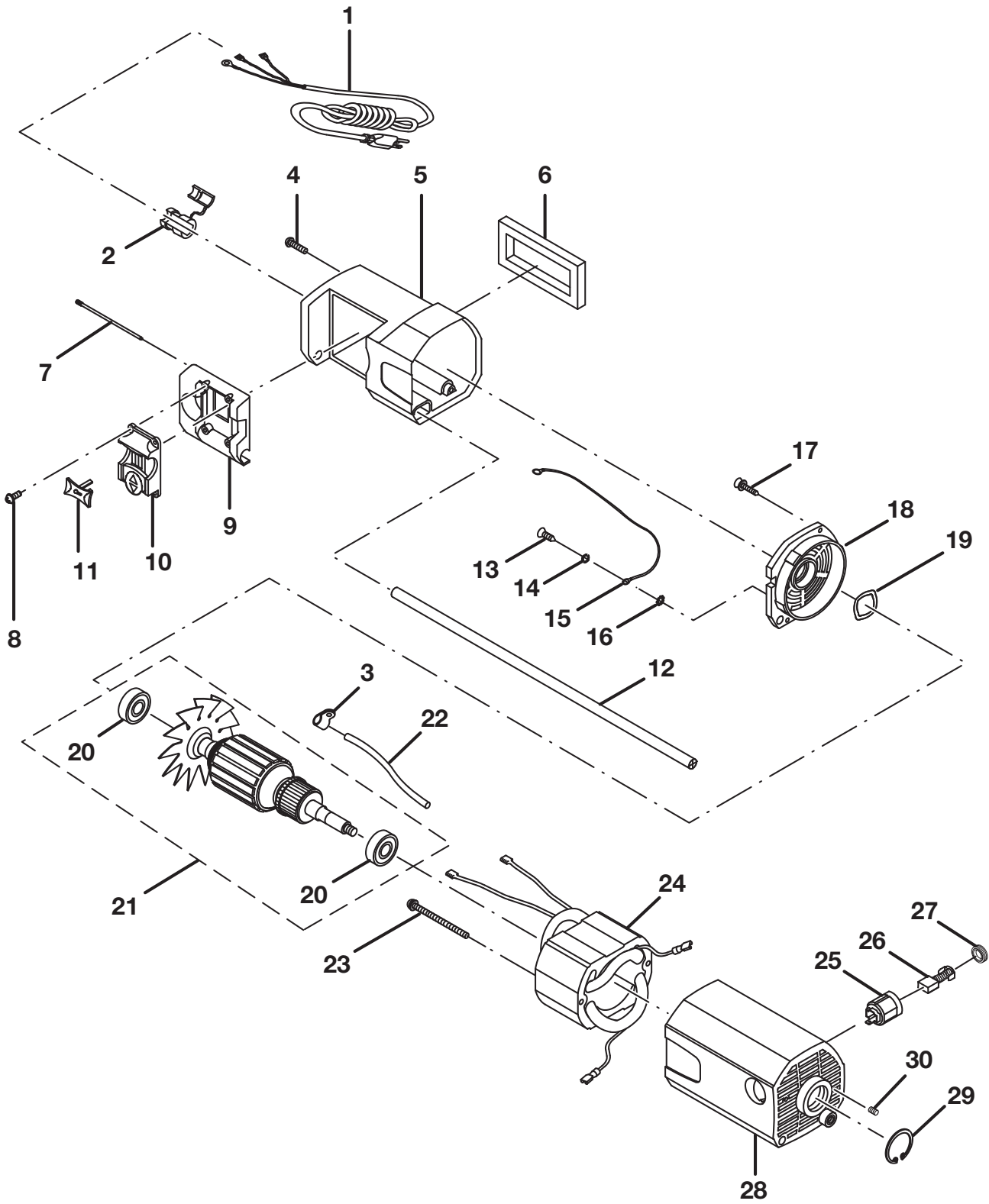

FIGURE B

RYOBI 13 in. PLANER – MODEL NUMBER AP1301

The model number will be found on a plate attached to the motor housing. Always mention the model number in all correspondence regarding your **PLANER** or when ordering repair parts.

PARTS LIST FOR FIGURE B

KEY NO.	PART NUMBER	DESCRIPTION	QTY.
1	089170101106	POWER CORD	1
2	089170101107	STRAIN RELIEF (6B3-2S).....	1
3	827767	CORD CLAMP.....	1
4	820240-7	* SCREW (M5 X 20 mm PAN HD.).....	2
5	089170101110	MOTOR HOUSING (REAR)	1
6	827740	FOAM GASKET	1
7	827797	SPECIAL SCREW	1
8	089170101113	* SCREW (M4 X 12 mm PAN HD.).....	4
9	089170101114	SWITCH SOCKET	1
10	089170101115	SWITCH (HY18-13) (INC. KEY NO. 11)	1
11	089170101116	SWITCH KEY.....	1
12	089170101117	MOTOR PIVOT ROD	1
13	820257-1	* SCREW (M5 X 8 mm PAN HD.).....	1
14	089170101119	* SPRING WASHER (M5).....	1
15	827812	LEAD WIRE WITH TERMINAL (300 mm ± 3 mm)	1
16	813314-8	LOCK WASHER (M5)	1
17	828946	* SCREW W/WASHER (M4.2 X 20 mm)	4
18	827707	MOTOR END CAP	1
19	820510-6	SPRING WASHER.....	1
20	820722-3	BALL BEARING (6201LLB).....	2
21	089170101126	ARMATURE ASSEMBLY (INC. KEY NO. 20)	1
22	827706	SLEEVE	1
23	828947	* SCREW W/WASHER (M4.8 X 75 mm)	2
24	089170101129	FIELD ASSEMBLY (INC. KEY NO. 22)	1
25	827809	BRUSH HOLDER	2
26	827811	BRUSH AND SPRING ASSEMBLY	2
27	827810	BRUSH CAP	2
28	089170101133	MOTOR HOUSING (FRONT).....	1
29	826551-1	RETAINING RING (RTW32)	1
30	821065-3	* SCREW (M5 X 12 mm HEX SOC.)	2
	983000828	OPERATOR'S MANUAL	
	983000828R	REPAIR SHEET (REV:01)	
	01-27-06		

* Standard Hardware Item – May Be Purchased Locally

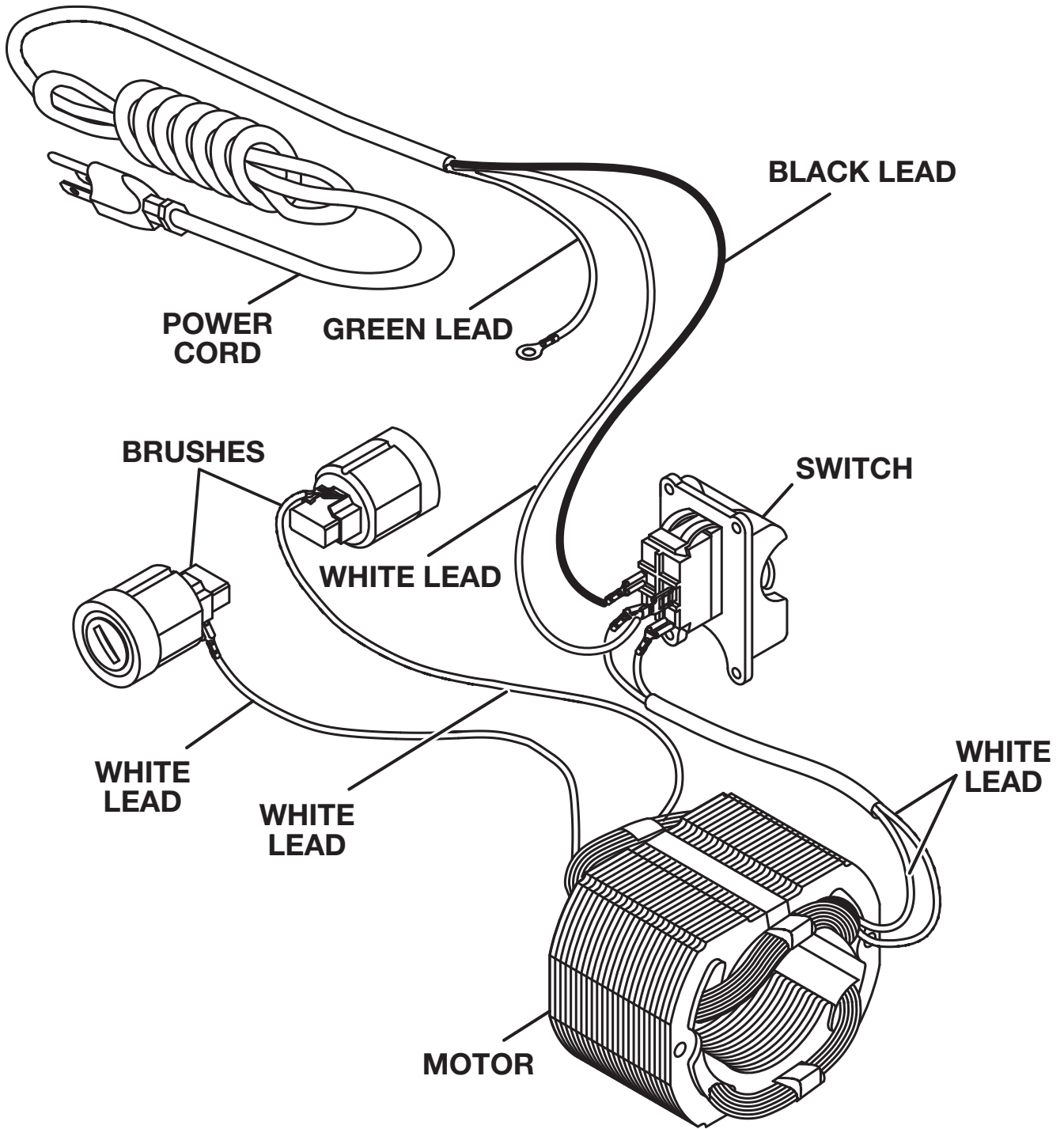

WIRING DIAGRAM